



E³A: Solar Hot Water Applications for the Home, Farm, or Ranch

Author: Bilo, Susan; Sarah Hamlen, Mike Vogel, and Milton Geiger, eds. E3A Program

Steps in the Solar Hot Water Series

1. Building and Site Assessment
2. Conservation and Efficiency
3. System Options
4. System Sizing
5. Costs
6. Installation
7. Operation and Maintenance
8. Solar Hot Water Collector Sizing Worksheet

Introduction

In the United States, water is typically heated using natural gas, electricity (generated from coal, natural gas, or hydro-power), or propane. Water heating can account for up to 20 percent of a home's total utility bill. Agricultural buildings and processes can use large amounts of heated water. For some dairy farms, water heating can account for 25 percent of the total energy used.

An alternative is to use the sun's energy as the fuel. Solar hot water systems are designed to capture the sun's energy to heat water. Solar hot water systems are also called solar thermal (heat) water systems and solar domestic (for homes) hot water systems.

How Energy Is Used In Homes (2005)

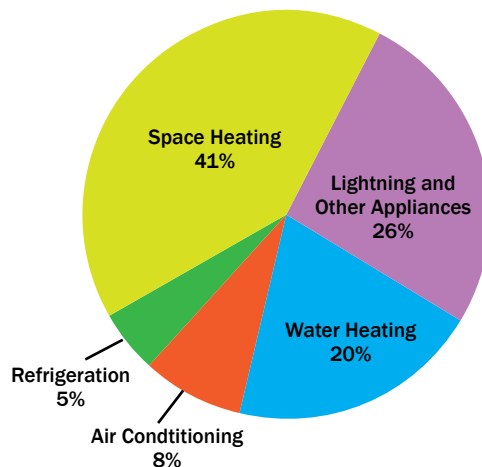

Source: U.S. Energy Information Administration, Residential Energy Consumption Survey 2005.

How do solar hot water systems work?

Simply put, the sun's energy is absorbed by a south-facing "collector" that heats a fluid (water or antifreeze). In warm climates, collector-heated water can be used directly. In cold climates, the fluid transfers its heat to potable water stored in a tank.

Solar Thermal - Domestic Hot Water System

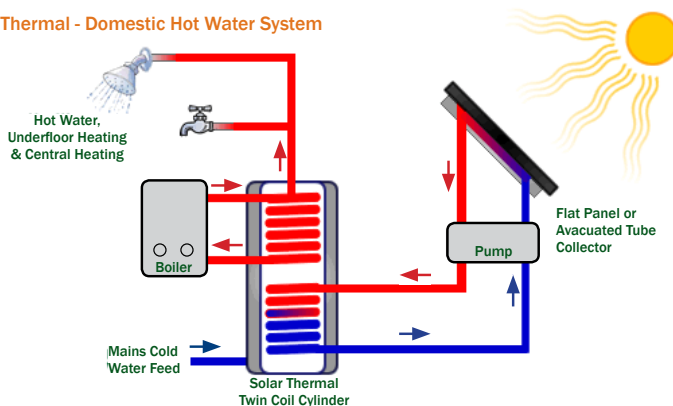

CC-BY-SA http://green.wikia.com/wiki/How_to_make_Your_House_more_Energy_efficient

While some areas are sunnier than others (Miami, Florida has more sunny days than Seattle, Washington), all states in the U.S. receive enough sun for operating solar hot water systems. Over 20,000 solar hot water systems were installed in the U.S. in 2008. Even in cold climates, these systems can provide a large percentage (up to 80+%) of hot water needed. The rest can be provided by a tankless (on-demand) water heater or a conventional storage tank system.



B-1279 | E3A-SH.0

©2015 E3A-SH.0 by Susan Bilo; Sarah Hamlen, Mike Vogel, and Milton Geiger eds. made available under a [Creative Commons Attribution-Non-Commercial 4.0 license \(international\)](https://creativecommons.org/licenses/by-nc/4.0/)

E3A: Solar Hot Water Applications for the Home, Farm, or Ranch is a peer-reviewed publication series.

Original available at: www.wyoextension.org/publications/

Suggested acknowledgment: Bilo, Susan; Sarah Hamlen, Mike Vogel, and Milton Geiger, eds. E3A: Solar Hot Water for the Home, Farm, or Ranch, Fact Sheet 0, Steps in the Solar Hot Water Series. E3A-SH.0. 2011.

Permission is granted to share, copy, and redistribute the material in any medium or format and adapt, remix, transform, and build upon the material for any purpose other than commercial, under the following terms:

Attribution – You must give appropriate credit, provide a link to the license, and indicate if changes were made. You may do so in any reasonable manner but not in any way that suggests the licensor endorses you or your use.

Benefits

Today's solar hot water systems are reliable, efficient, adaptable, and affordable. The purchase and installation cost of a residential solar hot water system can range from \$4,000 to \$10,000. When considering the "second price tag" of operating costs, solar hot water systems can be especially cost-effective compared to electric and propane water heaters. Average water heating bills often drop 50 to 80 percent. Systems can pay for themselves quickly. Payback time decreases when fuel costs increase; and, government and utility tax incentives and rebates can significantly reduce the final system cost further decreasing payback time. A properly designed and installed system can last up to 40 years.

While solar hot water systems can be used for radiant floor heating and indoor and outdoor swimming pools, the following factsheets only address agricultural-based buildings and processes and residential systems used to heat water for bathroom and kitchen fixtures and appliances.

Process

Use the folder's factsheets to determine if a solar hot water system will work for you. The information is basic and will help you discuss solar hot water systems knowledgeably with a company or installer. The sheets can be used separately or together for a step-by-step decision-making process.

1. Building & Site Assessment: Montana and Wyoming have ample sun for solar hot water systems, but there are building and site conditions to be considered.
2. Conservation & Efficiency: Conserving and using water and energy efficiently allows for a smaller, more efficient, and affordable system.

Notes

3. System Options: For Montana and Wyoming's cold climate, there are several systems that work well and do not freeze.
4. System Sizing: Proper sizing is important for a resource-efficient and cost-effective system.
5. Costs: System and operation and maintenance costs depend on various factors. Rebates and incentives lower the final purchase and installation cost.
6. Installation: Considerations for doing-it-yourself or hiring a contractor.
7. Operation & Maintenance: Routine inspections and maintenance will result in efficient and long-lived systems.
8. Solar Hot Water Collector Sizing Worksheet

References

National Renewable Energy Laboratory (produced) for the U.S. Department of Energy. (1999, September). *Solar Water Heating: Using the Sun to Heat Domestic Water Makes Sense in Almost Any Climate*. DOE/GO-10099-726.

Pressman, Andy. (2010). *Dairy Farm Energy Efficiency. A publication of Appropriate Technology Transfer for Rural Areas (ATTRA)*. National Center for Appropriate Technology, MT. <https://attra.ncat.org/attra-pub/dairyenergy.html>

Solar Energy Industries Association. (2009). *Solar Water Heating*. Retrieved January 21, 2011, from <http://www.seia.org>

U.S. Energy Information Administration. (2011). *Residential Energy Consumption Survey, 2005*. Retrieved January 21, 2011, from Using and Saving Energy in Homes: http://www.eia.gov/kids/energy.cfm?page=us_energy_homes-basics

Steps in the Solar Hot Water Series

1. Building and Site Assessment

2. Conservation and Efficiency

3. System Options

4. System Sizing

5. Costs

6. Installation

7. Operation and Maintenance

8. Solar Hot Water Collector Sizing Worksheet

E³A: Solar Hot Water Applications for the Home, Farm, or Ranch

Author: Bilo, Susan; Sarah Hamlen, Mike Vogel, and Milton Geiger, eds. E3A Program

Building and Site Assessment

Answering these questions will help you determine if a solar hot water system will work for your building or site.

1. Do you have a south-facing roof?

Because Montana and Wyoming are in the northern hemisphere, solar hot water collectors need to face south for maximum performance. This placement allows collectors to take full advantage of the sun's path in the sky. The sun shines longest on a building's south side. A slightly southeast or southwest placement will not result in significant loss in system performance.

- Yes! — Move to Question #2
- No — A solar hot water system may not work well.

You can add a south-facing roof extension or other structure if it can safely support collectors. Collectors can be mounted on a wall or the ground, but consider possible shading, snow drifts, lawn care, and vandalism.

Collectors can be mounted on east- or west-facing roofs to face south, but they stick-up, are highly visible, and can be viewed as unattractive. Architects and builders can address this by designing “solar ready” buildings and integrating solar technology components into the design.

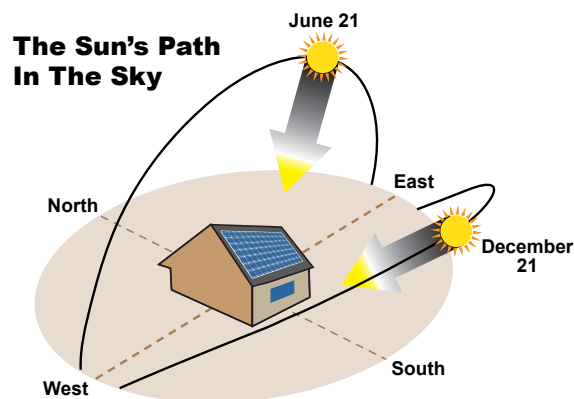

Solar hot water panels. Chequamegon Alliance for Sustainability
CC BY-NC-SA 2.0 <https://www.flickr.com/photos/cheqafs/4667407958/>



CC BY-NC 2.0 Clean Energy Resource Teams
<https://www.flickr.com/photos/mncerts/5346607907/in/album-72157632141554770/>



B-1279 | E3A-SH.1

©2015 E3A-SH.1 by Susan Bilo; Sarah Hamlen, Mike Vogel, and Milton Geiger eds. made available under a [Creative Commons Attribution-Non-Commercial 4.0 license \(international\)](https://creativecommons.org/licenses/by-nc/4.0/)

E3A: Solar Hot Water Applications for the Home, Farm, or Ranch is a peer-reviewed publication series.

Original available at: www.wyoextension.org/publications/

Suggested acknowledgment: Bilo, Susan; Sarah Hamlen, Mike Vogel, and Milton Geiger, eds. E3A: Solar Hot Water for the Home, Farm, or Ranch, Fact Sheet 1, Steps in the Solar Hot Water Series. E3A-SH.1. 2011.

Permission is granted to share, copy, and redistribute the material in any medium or format and adapt, remix, transform, and build upon the material for any purpose other than commercial, under the following terms:

Attribution — You must give appropriate credit, provide a link to the license, and indicate if changes were made. You may do so in any reasonable manner but not in any way that suggests the licensor endorses you or your use.

2. Does your roof have enough space for collectors?

For a residential system, the rule of thumb is that 20 square feet of collector roof/surface area is needed per person for the first two people in a household. Add 12-14 square feet of collector area for each additional hot water user.

- Yes! — Move to Question #3
- No — If your roof is not large enough for the collectors, consider a smaller system, extending your roof, or mounting collectors on a wall or the ground.



CC BY-NC 2.0 Clean Energy Resource Teams
<https://www.flickr.com/photos/mncerts/5222189380/in/album-72157632141554770/>

3. Is your roof unshaded?

Solar hot water systems are most efficient when collectors receive direct sun and are not shaded. Thus, consider possible shading from nearby buildings and the mature height of landscape plants such as trees.

- Yes! — Move to Question #4
- No — If the shade is from landscaping, consider removing the plants. If a structure is to be built that will shade any solar system you are considering, check local and state codes to see if you have “solar access” rights. Refer to Factsheet 6 Pre-Installation Considerations section.

4. What’s the angle of your roof?

If possible, use your latitude (46° for Helena, Mont.; 41° for Cheyenne, Wyo.) as the collector tilt angle to maximize the annual sun energy collected. Collectors can be installed at various angles depending on your hot water needs. Installers can mount collectors directly (flush) on an existing roof or

tilt at an angle that sheds snow easier or that produces more hot water in a particular season.

Flat Roofs

Collectors can be angled on flat roofs, but should not be placed flat (horizontal) because they will not receive enough sun (especially in winter) to make installation cost-effective. Plus, snow will not slide off and will block the sun making the building more dependent on the back-up system that is typically powered by natural gas, electricity, or propane.

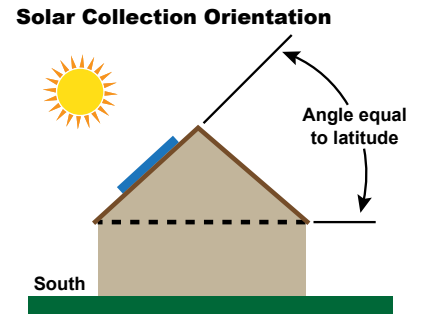

5. Is your roof in good condition?

Most roofs can safely support collector weight (about 160 pounds for two residential scale collectors). While innovative roof flashing can make collector removal easy, it’s less expensive and less labor intensive to make roof repairs before collectors are installed.

- Yes! — Move to What's Next
- No — If your roof needs to be replaced or repaired, complete that first and make sure it can handle the collectors’ weight. If considering a new roof, contact a solar hot water company for roof recommendations that might make system installation easier or less expensive.

What’s Next?

If you answered yes to every question or can make adjustments where you answered no, your building or site may be a good solar hot water system candidate. A system supplier or installer can provide a detailed assessment. Next, consider how conservation and efficiency measures can result in a more efficient and affordable system; then, learn about systems that work well in Montana and Wyoming.

Notes



STEP 2

Steps in the Solar Hot Water Series

1. Building and Site Assessment
2. Conservation and Efficiency
3. System Options
4. System Sizing
5. Costs
6. Installation
7. Operation and Maintenance
8. Solar Hot Water Collector Sizing Worksheet

E³A: Solar Hot Water Applications for the Home, Farm, or Ranch

Author: Bilo, Susan; Sarah Hamlen, Mike Vogel, and Milton Geiger, eds. E3A Program

Conservation and Efficiency: Water and energy conservation and efficiency provide the foundation for smaller, more efficient and affordable solar hot water systems.

While it's easy to get excited about solar and other renewable energy technologies, energy and water conservation and efficiency should be considered first.

Why? When you or a contractor sizes your system, it is based on the amount of water and energy you use. The less you use, the smaller, more efficient and cost-effective the system will be.

The initial purchase as well as operation and maintenance costs will be less. You will reduce your water, sewer, natural gas, and electric bills, and, reduce use of your back-up system that is typically powered by natural gas, electricity, or propane.

Buildings that do not waste water (conserve) and use water-efficient fixtures, appliances, and machinery can reduce water use up to 30 percent. Households (without wells) spend as much as \$500 per year on water and sewer bills. Simple changes for using water more efficiently can reduce utility bills by about \$170 per year.

Also, when we all use water more efficiently, we reduce the need for new tax-payer funded water supply infrastructure and wastewater treatment facilities. People who receive water from wells reduce the amount of water drawn from aquifers.

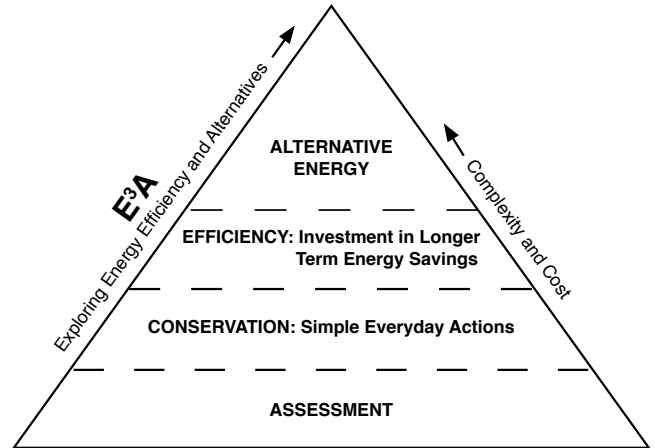

Water Conservation & Efficiency Tips

Whether hot or cold, using water wisely has many benefits. Solar hot water systems provide water for showers/baths, kitchen and bathroom faucets, clothes washers, and dishwashers for homes. Heated water is also used in agriculture buildings for processes and cleaning.



If your home or building was built before 1992, consider installing **WaterSense-labeled low-flow showerheads, faucet aerators, and toilets.** Installing a WaterSense

showerhead, which uses ≤ 2.0 gallons per minute versus 2.5+ gallons per minute with a standard showerhead, could reduce hot water use by 2,300 gallons. WaterSense faucets

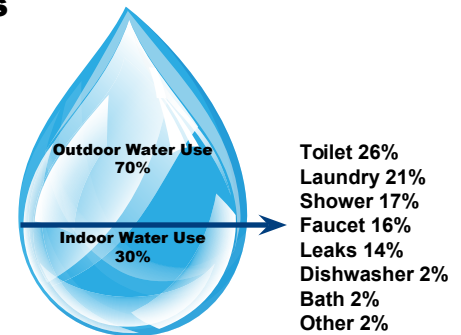

Source: Cape Fear Public Utility Authority <http://www.cfpua.org/299/Water-Saving-Tips-Tools>



B-1279 | E3A-SH.2

©2015 E3A-SH.2 by Susan Bilo; Sarah Hamlen, Mike Vogel, and Milton Geiger eds. made available under a [Creative Commons Attribution-Non-Commercial 4.0 license \(international\)](https://creativecommons.org/licenses/by-nc/4.0/)

E3A: Solar Hot Water Applications for the Home, Farm, or Ranch is a peer-reviewed publication series.

Original available at: www.wyoextension.org/publications/

Suggested acknowledgment: Bilo, Susan; Sarah Hamlen, Mike Vogel, and Milton Geiger, eds. E3A: Solar Hot Water for the Home, Farm, or Ranch, Fact Sheet 2, Steps in the Solar Hot Water Series. E3A-SH.2. 2011.

Permission is granted to share, copy, and redistribute the material in any medium or format and adapt, remix, transform, and build upon the material for any purpose other than commercial, under the following terms:

Attribution — You must give appropriate credit, provide a link to the license, and indicate if changes were made. You may do so in any reasonable manner but not in any way that suggests the licensor endorses you or your use.

typically reduce water use by 30 percent. Be sure to fix water leaks because they can account for up to 15 percent of your water bill.

WaterSense labeled products must undergo independent, third-party testing and certification to ensure they meet the U.S. Environmental Protection Agency's (EPA) criteria for both efficiency and performance.

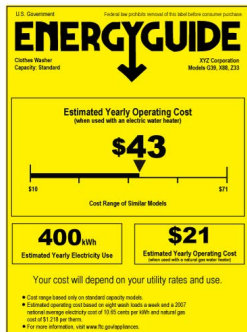

<https://www.consumer.ftc.gov/blog/shopping-home-appliance>

When purchasing appliances and machinery, look for the **Energy Star** Label. An Energy Star, high-efficiency **clothes washer** often uses 50 percent less water and energy than a traditional clothes washer. Many high-efficiency clothes washers clean clothes effectively using cold water. For **dishwashers**, look for the Energy Star label and compare the yellow **EnergyGuide** labels to compare energy use.

For more water conservation tips, visit: www.epa.gov/region01/eco/drinkwater/water_conservation_residents.html

Insulate hot water storage tanks and pipes (especially if located in an unheated space). It's cheap, easy, and pays for itself quickly. Heat loss through the tank and pipes (called standby losses) can account for 20 percent of your water heating bill. For tips on reducing hot water use, visit: http://www.energysavers.gov/your_home/water_heating/index.cfm/mytopic=13050

While not related to heated water, it is important to mention that farms can conserve large amounts of water (and energy) by switching to a linear/pivot system and drip irrigation practices.

Notes

Did You Know?

While it is obvious energy is required to heat water, a large amount of energy is also required to treat (drinking water standards) and pump water. It also takes a lot of energy to treat our wastewater before it is pumped into a river or other body of water. According to the EPA, American public water supply and treatment facilities consume about 56 billion kilowatt-hours per year — enough electricity to power more than 5 million homes for an entire year.

References

Energy Trust of Oregon. (2010, April). *Reduce Irrigation Energy Costs*. Retrieved April 30, 2011, from: http://energytrust.org/library/forms/PE_BRO_Irrigation.pdf

Sustainable Agriculture Research and Education (SARE). (2008, February). *Clean Energy Farming: Cutting Costs, Improving Efficiencies, Harnessing Renewables*. Retrieved April 30, 2011, from: <http://www.sare.org/Learning-Center/Bulletins/National-SARE-Bulletins/>

U.S. Department of Energy. (2010, October). *Reduce Hot Water Use for Energy Savings*. Retrieved January 25, 2011, from: http://www.energysavers.gov/your_home/water_heating/index.cfm/mytopic=13050

U.S. Environmental Protection Agency. (2011). *WaterSense: Benefits of Water Efficiency*. Retrieved February 2, 2011, from: <http://www.epa.gov/watersense/>

U.S. Environmental Protection Agency. (2011) *WaterSense: What Are the Environmental Benefits of Water Efficiency?* Retrieved February 2, 2011, from: <http://www.epa.gov/watersense/>



STEP 3

Steps in the Solar Hot Water Series

1. Building and Site Assessment
2. Conservation and Efficiency
- 3. System Options**
4. System Sizing
5. Costs
6. Installation
7. Operation and Maintenance
8. Solar Hot Water Collector Sizing Worksheet

E³A: Solar Hot Water Applications for the Home, Farm, or Ranch

Author: Bilo, Susan; Sarah Hamlen, Mike Vogel, and Milton Geiger, eds. E3A Program

System Options

Solar hot water systems can be designed for a variety of climates. Most systems include a solar collector, pump, controller, piping, and a back-up source. Typically, the existing conventional water heater is used as the back-up. How does it work? Collectors absorb the sun's energy to heat either water or antifreeze fluid. In non-freezing climates, collector-heated water can be used directly. In cold climates, collector-heated fluid goes to a storage tank where its heat is transferred (given up) to the potable tank water. Once the heat transfers, the cooled fluid is pumped back to the collector to be reheated by the sun. There are several system types that prevent collector fluids from freezing, and they work well in cold climate states such as Montana and Wyoming. The system options discussed here apply to small systems such as those used for homes. Consult with a qualified solar hot water system installer regarding larger systems.

Collectors

Flat plate and evacuated tube collectors are the two types commonly used for cold climate solar hot water systems. There are other collector types than can be used for warm climates and larger commercial and industrial applications.

Flat plate

Flat plate collectors are made of copper flow tubes connected to a dark absorber plate within an insulated, weatherproof box covered with hail-resistant tempered glass or plastic. Water or antifreeze can be heated by these collectors.



This house in Golden, Colorado uses flat plate water heating panels
Photo by Warren Getz, NREL 00655
<http://images.nrel.gov/viewphoto.php?imageld=6308655>

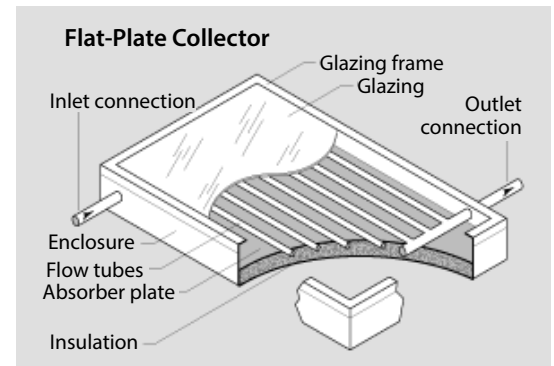

Picture provided as public domain by the US Dept. of Energy
https://commons.wikimedia.org/wiki/File:Flat_plate_glazed_collector.gif

Evacuated tube

Evacuated tube collectors are composed of rows of parallel, clear glass tubes. Each tube has an inner tube that absorbs solar energy. Air is removed (evacuated) from the space



B-1279 | E3A-SH.3

©2015 E3A-SH.3 by Susan Bilo; Sarah Hamlen, Mike Vogel, and Milton Geiger eds. made available under a [Creative Commons Attribution-Non-Commercial 4.0 license \(international\)](https://creativecommons.org/licenses/by-nc/4.0/)

E3A: Solar Hot Water Applications for the Home, Farm, or Ranch is a peer-reviewed publication series.

Original available at: www.wyoextension.org/publications/

Suggested acknowledgment: Bilo, Susan; Sarah Hamlen, Mike Vogel, and Milton Geiger, eds. E3A: Solar Hot Water for the Home, Farm, or Ranch, Fact Sheet 3, Steps in the Solar Hot Water Series. E3A-SH.3. 2011.

Permission is granted to share, copy, and redistribute the material in any medium or format and adapt, remix, transform, and build upon the material for any purpose other than commercial, under the following terms:

Attribution — You must give appropriate credit, provide a link to the license, and indicate if changes were made. You may do so in any reasonable manner but not in any way that suggests the licensor endorses you or your use.

inside the glass tubes forming a vacuum that reduces heat loss. Water or antifreeze can be heated by these collectors. They work well in cloudy conditions, but are not as hail-resistant as flat plate collectors

Complete System

Two system types that work well in Montana and Wyoming are called “active systems” because they use pumps and other electronic equipment to move fluids and operate the system. “Passive systems” have no moving parts and rely on gravity or convection to move fluids and are typically used in warmer climates. Active systems can be Open Loop or Closed Loop.

Open Loop = Direct

Collectors directly heat the water.

- Hard or acidic water can cause scale and corrosion in tubes and pipes.
- A recirculation system pumps warm storage tank water to the collector during freezing weather, but **best for mild climates.**

Closed Loop = Indirect

Collectors indirectly heat water with heat-transfer fluids and a heat exchanger.

Two active, closed loop systems that work well in cold climates are described directly below.

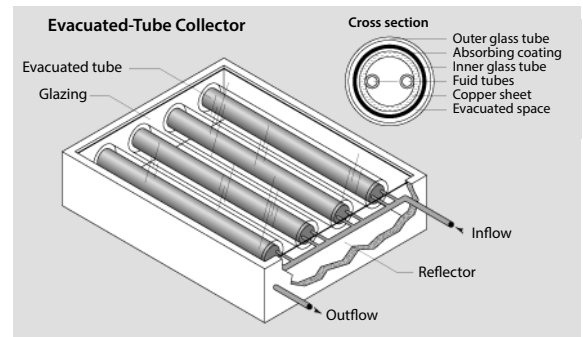

Picture provided as public domain by the US Dept. of Energy
https://commons.wikimedia.org/wiki/File:Evacuated_tube_collector.gif

ANTIFREEZE SYSTEM

Heat-transfer fluid = Propylene-Glycol

- Uses a low freezing-point antifreeze (typically a food-grade propylene glycol + water mixture) in the collector to absorb the sun’s heat energy.
- A pump circulates the antifreeze through the collector pipes and to the storage tank.
- In the storage tank, a heat exchanger transfers the antifreeze’s heat to the storage tank water.
 - Solar-powered electric pumps can be used.
 - Tilting collectors more toward the lower-angled, winter sun (latitude +15 degrees) minimizes summertime tank overheating.

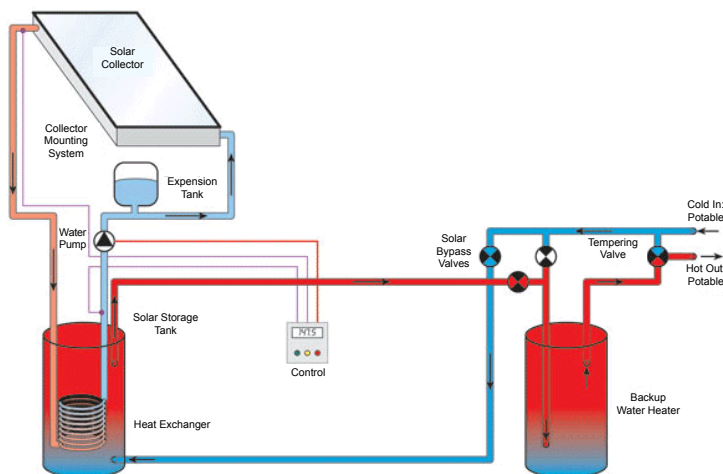

Antifreeze (Glycol) System, Reprinted with permission.
 ©2011 Home Power Inc., www.homepower.com

DRAINBACK SYSTEM

Heat-transfer fluid = Water

- Uses water in the collector to absorb the sun’s heat energy.
- A pump circulates water through the collector pipes; gravity allows the heated water to drain to the storage tank.
- In the storage tank, a heat exchanger transfers the water’s heat to the storage tank water.
 - Minimal maintenance.
 - When extreme temperatures (hot or cold) are detected, the controller turns the pump off allowing the collector water to drain to a reservoir. Thus, no summer overheating issues.

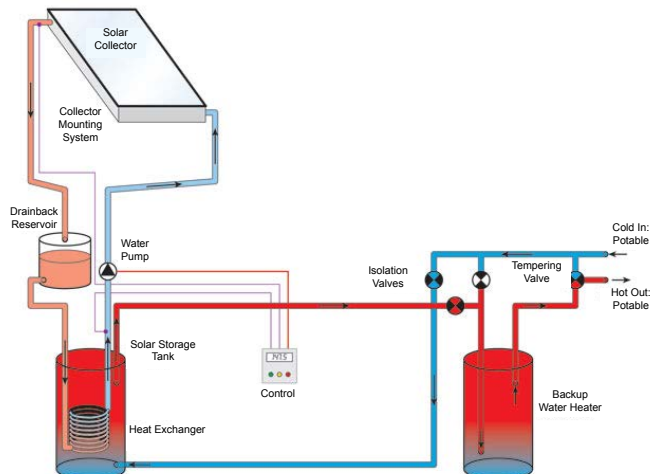

Drainback (Water) System, Reprinted with permission.
 ©2011 Home Power Inc., www.homepower.com

Back-Up Water Heater Systems

Solar hot water systems can generate a large portion of your hot water (especially in warmer months), but typically not 100% in colder climates. Back-up systems turn on when there are prolonged cloudy days or excessive hot water demands cannot be met by the solar system. For an existing home or building, the existing conventional hot water system can be used as the back-up for the new solar hot water system. For a new home or building, a back-up system is installed along with the solar hot water system.

An increasing number of home and business owners are considering tankless water heaters as a primary water heating system. Tankless heaters also serve as excellent back-ups for solar hot water systems. Tankless water heaters are also called on-demand or instantaneous water heaters.

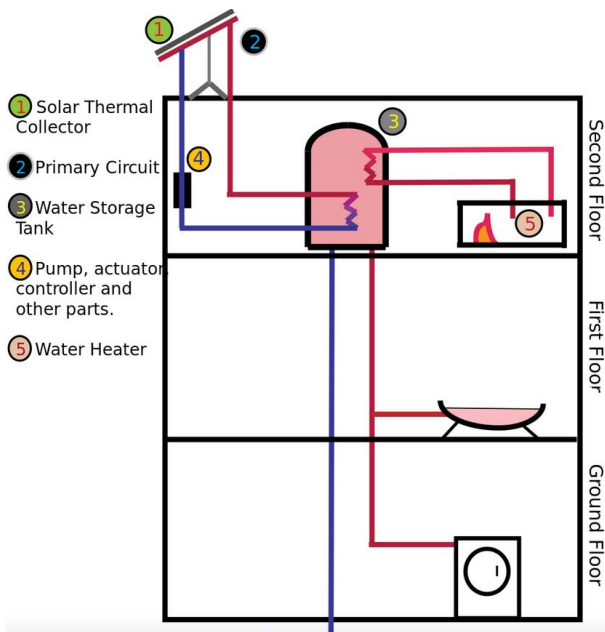

Hvatum at [en.wikipedia.org \[CC BY 3.0 \(http://creativecommons.org/licenses/by/3.0\)\]](http://en.wikipedia.org/wiki/File:Active_Solar_Water_Heater_Diagram.svg), via Wikimedia Commons https://commons.wikimedia.org/wiki/File:Active_Solar_Water_Heater_Diagram.svg

Tankless/On-Demand Water Heaters

The most commonly used water heater systems entail storage tanks that keep water heated continuously whether the water is needed or not. Keeping water heated at all times can account for 15 percent or more of a water heating bill. Tankless (no storage tanks) water heaters only use energy to heat water when it is needed. This is how they conserve energy and reduce your utility bill.

How do they work?

A flow sensor detects when the hot water faucet is turned on or the warm/hot water selection is made for an appliance. For a gas-powered tankless system, the gas valve opens and the burner fires-up. The system measures the incoming

water temperature and calculates how quickly the water should flow past the burner through to the faucet or appliance.

While these systems can supply a limitless amount of heated water, there are flow rate limits; thus, they must be sized for your hot water needs. An average flow rate is two to five gallons per minute.

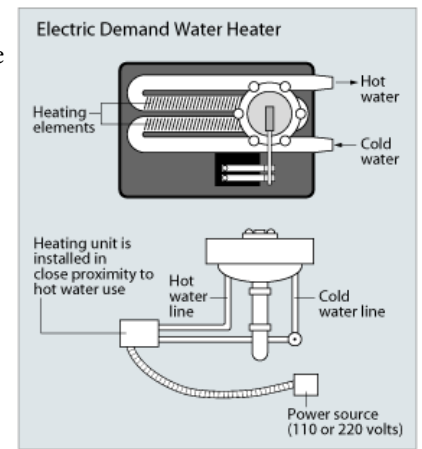

Courtesy U.S. Department of Energy <http://energy.gov/energysaver/articles/tankless-or-demand-type-water-heaters>

Gas-powered units

Gas-powered units provide higher flow rates than electric-powered units. If considering a gas-powered model, ask the manufacturer how much gas the pilot light uses. If you purchase one with a standing pilot light, it can be turned off when not in use to conserve energy. Another energy saving option is an intermittent ignition device. If a lot of hot water is used at the same time each day in your home or building, you might need more than one unit.

Conventional tank water heaters

While conventional storage tank water heaters are less expensive to buy (first price tag), they are more expensive to fuel and maintain (the second price tag). Storage tank heaters vary in efficiency and can last about 15 years; whereas, tankless systems are very efficient (up to 96 percent), and can last 20 or more years.

Note: Not all tankless water heaters will work with a solar hot water system, so be sure to inquire. Some manufacturers have special models that work with solar hot water systems. Also, if considering a gas-powered tankless water heater, determine if your existing gas line can handle the larger natural gas demand (based on distance to the gas meter, other gas appliances, etc.)

SRCC Certification

How can you be sure you are buying a reliable, high-performance solar hot water system?

Make sure to ask for and buy Solar Rating and Certification Corporation (SRCC) certified collectors and complete systems. SRCC tests performance and certifies almost every solar

hot water heater on the market. SRCC is an independent,

non-profit organization that determines system performance in accordance with national ratings standards. See www.solar-rating.org for complete and up-to-date information.





STEP 4

Steps in the Solar Hot Water Series

1. Building and Site Assessment
2. Conservation and Efficiency
3. System Options
- 4. System Sizing**
5. Costs
6. Installation
7. Operation and Maintenance
8. Solar Hot Water Collector Sizing Worksheet

E³A: Solar Hot Water Applications for the Home, Farm, or Ranch

Author: Bilo, Susan; Sarah Hamlen, Mike Vogel, and Milton Geiger, eds. E3A Program

System Sizing

Proper System Sizing

One of the most important steps in buying a solar hot water system is to make sure it is sized properly for your hot water needs. If too large, you wasted money on a system that makes more hot water than you need. If too small, you spend extra money using your back-up heater that is powered by natural gas, electricity, or propane. The appropriate size and number of collectors, storage tank size, and overall system type that works best for your hot water needs will result in a smaller, more resource-efficient, and cost-effective system.

Collector Sizing / Roof Space

Flat plate collectors range in size from 20 to 48 square feet and can weigh from 80 to 150 pounds. Dimensions range from 3x6 feet to 4x10 feet with a 3-inch thickness. Evacuated tube collector sizes depend on the number of tubes used. A 20-tube collector (about 6x7 feet in dimension) would provide enough hot water for one to three people. They weigh more than flat plate collectors.

For a quick residential system estimate, the general rule of thumb is that your south-facing roof/surface needs a minimum of 20 square feet of collector area for each of the first two people in the home. For each additional person using hot water, add a minimum of 12 to 14 square feet. Using these guidelines, 52 square feet of south-facing roof or other surface area is needed for collectors that can provide 100 percent of the hot water for three people. Conserving water and installing water-efficient fixtures and appliances can reduce the size of collectors and overall system needed.

| | |
|--|-------------------------------|
| For example, if three people lived in a home: | |
| two people = | 40 square feet |
| third person= | <u>+12 square feet</u> |
| | 52 square feet |

For an assessment specific to your hot water use, complete **Step 8: Solar Hot Water Collector Sizing Worksheet.**

Solar Storage Tank Sizing

Some companies sell one-tank solar hot water systems (the tank stores solar-heated water and serves as a back-up), but most building owners keep the existing hot water heater as a back-up and purchase a new storage tank for solar-heated water.

The rule of thumb for storage tank size is based on an average of 20 gallons of hot water per person per day.

| # of People | Storage Tank Volume (in gallons) |
|-------------|----------------------------------|
| 1 to 3 | 30-60 |
| 3 to 4 | 80 |
| 4 to 6 | 120 |



B-1279 | E3A-SH.4

©2015 E3A-SH.4 by Susan Bilo; Sarah Hamlen, Mike Vogel, and Milton Geiger eds. made available under a [Creative Commons Attribution-Non-Commercial 4.0 license \(international\)](https://creativecommons.org/licenses/by-nc/4.0/)

E3A: Solar Hot Water Applications for the Home, Farm, or Ranch is a peer-reviewed publication series.

Original available at: www.wyoextension.org/publications/

Suggested acknowledgment: Bilo, Susan; Sarah Hamlen, Mike Vogel, and Milton Geiger, eds. E3A: Solar Hot Water for the Home, Farm, or Ranch, Fact Sheet 4, Steps in the Solar Hot Water Series. E3A-SH.4. 2011.

Permission is granted to share, copy, and redistribute the material in any medium or format and adapt, remix, transform, and build upon the material for any purpose other than commercial, under the following terms:

Attribution — You must give appropriate credit, provide a link to the license, and indicate if changes were made. You may do so in any reasonable manner but not in any way that suggests the licensor endorses you or your use.

For active systems (those typically used in Montana and Wyoming), a more accurate estimate uses the following guideline: 1.5 gallons of storage tank capacity is needed per square foot of collector area.

This helps prevent system overheating when hot water demand is low.

For our example, 52 square feet of collector area x 1.5 = 78 gallons of storage tank volume needed; thus, an 80-gallon tank would be used.

**Example: 3 person household
x 20 gallons of hot water per day
= 60-gallon storage tank**

System Efficiency

While the type and size of a solar hot water system are important, so is efficiency. The more efficient the system, the quicker it pays for itself. Two efficiency numbers to be aware of and ask about:

- Solar Energy Factor (SEF): this number ranges from 1.0 to 11 where the higher the number, the more efficient the system. SEF is determined by the amount of energy delivered to the system divided by the electrical or gas energy put into the system.
- Solar Fraction (SF): this number ranges from 0 to 1.0 and is the fraction of your water heating energy requirement that is provided by the sun. The higher the SF number, the more efficient the system and the more the sun's energy is contributing to your water heating (reducing the energy used by a backup heater).

If you refer to the Solar Rating and Certification Corporation's (SRCC) website and compare complete systems (under the OG 300 Directory), you can compare SEF and SF ratings. System ratings are for all components of

a system: collector, tank, pumps, motors, valves, piping, etc. SRCC system ratings are only for residential-scale systems. The OG 100 Directory provides only individual collector rating information.

While the rules of thumb and sizing worksheet provide a ballpark idea of collector and storage tank sizes, solar hot water system companies and installers can conduct a more precise assessment based on your water use, roof tilt, latitude, solar resource, and seasonal temperature variations.

Computer Programs: If you have access to a computer, there are programs that allow you to input your information to get an idea of system size, cost, etc. One to try is Solar Estimate at: www.Solar-Estimate.org

References

National Renewable Energy Laboratory (produced) for the U.S. Department of Energy. (2003, December). *A Consumer's Guide: Heat Your Water with the Sun*. DOE/GO-102003-1824.

National Renewable Energy Laboratory (produced) for the U.S. Department of Energy. (1996, March). *Solar Water Heating*. DOE/GO-10096-050.

U.S. Department of Energy. (2010, October). *Sizing a Solar Water Heating System*. Retrieved January 19, 2011, from: http://www.energysavers.gov/your_home/water_heating/index.cfm/mytopic=12880

U.S. Department of Energy. (2010, October). *Solar Water Heater Energy Efficiency*. Retrieved February 8, 2011, from: http://www.energysavers.gov/your_home/water_heating/index.cfm/mytopic=12900

Notes



STEP 5

Steps in the Solar Hot Water Series

1. Building and Site Assessment
2. Conservation and Efficiency
3. System Options
4. System Sizing
- 5. Costs**
6. Installation
7. Operation and Maintenance
8. Solar Hot Water Collector Sizing Worksheet

E³A: Solar Hot Water Applications for the Home, Farm, or Ranch

Author: Bilo, Susan; Sarah Hamlen, Mike Vogel, and Milton Geiger, eds. E3A Program

Costs

Based on information compiled by the National Renewable Energy Laboratory and RS Means “Green Building Cost Data” from 2011, small solar water heating systems (like those used for homes) can cost between \$187 and \$199 per square foot of collector area. Larger, central systems that could be used for agricultural-based purposes can average about \$60 per square foot of collector area. For the initial residential example, 52 square feet of collector area x \$187 = \$9,724 for the complete system. This is a rule-of-thumb estimate, and any available rebates or tax incentives reduce the final cost.

Once you know the system option that will work best for you, determine the purchase and installation costs of several systems you are considering. The “second price tag” takes back-up system fuel costs and operation and maintenance costs into consideration. After calculating yearly operating costs for each system, you can make a complete cost comparison.

Calculating Yearly Operating Costs

To estimate the yearly operating cost, first collect the following information:

- The solar hot water system’s Solar Energy Factor (SEF)
- The cost and fuel type to be used for the back-up system

Gas back-up

For a gas back-up, determine the cost of the fuel in therms or British thermal units (Btu). Utility bills may show gas prices in units of therms (1 therm = 100,000 Btu) or Dekatherms (1 Dekatherm = 10 Therms). Use the formula: $365 \times (0.4105 \div \text{SEF}) \times \text{fuel cost} =$ estimated yearly cost of operation.

Example for a **gas** back-up system:

$$365 \times (0.4105 \text{ divided by } 2) \times \$ 0.98 = \$73.42$$

Where: 365 = days in a year; 0.4105 = formula constant for therms; (use 41,045 for Btus); 2 = Solar Energy Factor; \$ 0.98 (98 cents) = cost per therm

Electric back-up

For an electric back-up, determine how much you pay for a kWh of electricity, then use the formula: $365 \times (12.03 \div \text{SEF}) \times \text{electricity cost (kWh)} =$ estimated yearly cost of operation.

Example for an **electric** back-up system:

$$365 \times (12.03 \text{ divided by } 3) \times \$ 0.10 = \$146.37$$

Where: 365 = days in a year; 12.03 = formula constant; 3 = Solar Energy Factor; \$ 0.10 (10 cents) = cost per kWh

Back-up system costs and maintenance costs contribute to yearly operation costs. Solar hot water system maintenance costs typically run \$25-\$30 every 3-5 years.

Once you know the solar hot water systems’ purchase and installation costs and have calculated yearly operating costs for each, you can compare and determine simple payback.



B-1279 | E3A-SH.5

©2015 E3A-SH.5 by Susan Bilo; Sarah Hamlen, Mike Vogel, and Milton Geiger eds. made available under a [Creative Commons Attribution-Non-Commercial 4.0 license \(international\)](https://creativecommons.org/licenses/by-nc/4.0/)

E3A: Solar Hot Water Applications for the Home, Farm, or Ranch is a peer-reviewed publication series.

Original available at: www.wyoextension.org/publications/

Suggested acknowledgment: Bilo, Susan; Sarah Hamlen, Mike Vogel, and Milton Geiger, eds. E3A: Solar Hot Water for the Home, Farm, or Ranch, Fact Sheet 5, Steps in the Solar Hot Water Series. E3A-SH.5. 2011.

Permission is granted to share, copy, and redistribute the material in any medium or format and adapt, remix, transform, and build upon the material for any purpose other than commercial, under the following terms:

Attribution – You must give appropriate credit, provide a link to the license, and indicate if changes were made. You may do so in any reasonable manner but not in any way that suggests the licensor endorses you or your use.

For example:

| Solar Hot Water System | Purchase & Installation Cost | SEF | Estimated Yearly Operating Cost |
|------------------------|------------------------------|-----|---------------------------------|
| System A | \$9,500 | 2 | \$170 |
| System B | \$10,000 | 3 | \$120 |

The additional purchase price of the more efficient (higher SEF) System B is \$500 ($\$10,000 - \$9,500 = \500), but the yearly operating cost of System B is \$50 less per year ($\$170 - \$120 = \50). The more efficient solar hot water system will pay for itself in 10 years or less. For any comparison, simple payback is calculated by dividing the system price difference by the yearly operating savings: **\$500 divided by \$50 = 10-year simple payback.**

Note: Payback periods decrease when fuel costs increase. And, government and utility rebates and tax incentives can significantly reduce your final system cost further decreasing the payback period.

Other Cost Considerations

When an installer visits your home or building, he or she will consider how the solar hot water system components will be integrated into your home's structure and tie-in with the existing hot water system. Installation costs can vary based on where collectors are located and the piping distance to the storage tank(s).

Incentives That Lower Costs

There are a variety of federal, state, and local government and utility incentives for energy efficiency and renewable energy. These incentives vary by state and in the length of time they are available. The Department of Energy's Database of State Incentives for Renewables and Efficiency (DSIRE) (<http://dsireusa.org/>) tracks available tax credits, rebates and other incentives available to reduce your system's final cost.

Final Cost with Current Incentives (Using the \$9,724 residential system example)

- Federal Income Tax Credit (expires Dec. 31, 2016) is 30% of the system cost (after any utility rebates): $\$9,724 \times .30 = \$2,917$ tax credit.

Note: To qualify for this federal tax credit, "solar water heating property must be certified by SRCC or a comparable entity endorsed by the state where the system is installed. At least half of the energy used to heat the dwelling's water must be from solar."

- Montana State Income Tax Credit (currently no expiration date) is \$500 for one taxpayer; \$1,000 for a household: $\$9,724 - \$2,917 - \$1,000 = \$5,807$ final purchase + installation cost.

Note: Montana currently provides property tax exemptions for renewable energy systems, but some have expiration dates. Contact the Montana State Department of Revenue for current and applicable information.

If you want to compare conventional water heating system costs with solar hot water system costs, visit: http://www.solar-rating.org/facts/system_ratings.html, and scroll down to the Comparing System Costs section.

References

U.S. Department of Energy. (2010, October). *Estimating a Solar Water Heating System's Cost*. Retrieved January 19, 2011, from: http://www.energysavers.gov/your_home/water_heating/index.cfm/mytopic=12910

Notes



STEP 6

Steps in the Solar Hot Water Series

1. Building and Site Assessment
2. Conservation and Efficiency
3. System Options
4. System Sizing
5. Costs
- 6. Installation**
7. Operation and Maintenance
8. Solar Hot Water Collector Sizing Worksheet

E³A: Solar Hot Water Applications for the Home, Farm, or Ranch

Author: Bilo, Susan; Sarah Hamlen, Mike Vogel, and Milton Geiger, eds. E3A Program

Installation

Pre-Installation Considerations

Before installing a solar hot water system, check local building **codes**, subdivision **covenants**, and zoning ordinances or **regulations**. Contact your local zoning and building department representatives to determine requirements. If you live in a subdivision with a homeowner's association (HOA), review the covenants and contact the HOA Board or the management company. You may need a building permit if installing on an existing home. If you are the first in your HOA or town to install a renewable energy system, you may need to educate building code officials and local representatives.

Possible installation issues might include historic district guidelines and future shading. Will any trees on your property or nearby property grow and shade the system? Be sure to communicate with neighbors about your plans and determine if they might plant trees or add a second story to a home that may shade your system. Some government jurisdictions have solar access zoning regulations that prevent the blocking of the sun required for operation of any solar energy system. Montana law (70-17-301) allows the creation of easements to protect solar and wind energy rights. This requires negotiation with neighboring property owners.

Who Will Install Your System?

Because proper installation of a solar hot water system entails numerous considerations and requires attention to safety (roof work, electrical hook-ups, etc.), hiring a qualified solar hot water company or contractor is recommended. Some manufacturers will extend a system's warranty if installed by one of their trained contractors. And, some utility rebates will only be given if a system is installed by a trained professional. Protect yourself and feel confident you are hiring a qualified professional by asking questions about their level of experience, licensing, certifications, and customer service.

Experience

Does the company or individual contractor have experience installing and providing maintenance for the system you want installed? Ask for the contact information of other customers, and if possible, take time to see those systems and ask the owners about their experience with the system and the level of customer service received.

Licenses

Some states require solar hot water system installers to have a plumber's license or a solar contractor's license. Confirm licensing with your state's licensing boards. The State of Montana currently does not require licensing for the installation of any renewable energy systems.

Insurance

Be sure to ask about and see confirmation of liability and workman's compensation insurance.



B-1279 | E3A-SH.6

©2015 E3A-SH.6 by Susan Bilo; Sarah Hamlen, Mike Vogel, and Milton Geiger eds. made available under a [Creative Commons Attribution-Non-Commercial 4.0 license \(international\)](https://creativecommons.org/licenses/by-nc/4.0/)

E3A: Solar Hot Water Applications for the Home, Farm, or Ranch is a peer-reviewed publication series.

Original available at: www.wyoextension.org/publications/

Suggested acknowledgment: Bilo, Susan; Sarah Hamlen, Mike Vogel, and Milton Geiger, eds. E3A: Solar Hot Water for the Home, Farm, or Ranch, Fact Sheet 6, Steps in the Solar Hot Water Series. E3A-SH.6. 2011.

Permission is granted to share, copy, and redistribute the material in any medium or format and adapt, remix, transform, and build upon the material for any purpose other than commercial, under the following terms:

Attribution — You must give appropriate credit, provide a link to the license, and indicate if changes were made. You may do so in any reasonable manner but not in any way that suggests the licensor endorses you or your use.

Certifications

Many installers take specialized training and exams to receive certifications. The North American Board of Certified Energy Practitioners (NABCEP) is one group that provides training and certification for solar hot water and other renewable energy system professionals. The NABCEP website lists NABCEP-certified professionals in each state (www.nabcep.org).

Finding an Installer

The Solar Energy Industries Association and its state chapters provide lists of solar energy system companies by state or city. The Montana Renewable Energy Association (MREA) website (www.montanarenewables.org) provides information on Montana companies that install renewable energy systems, including solar hot water, and lists each company's certifications. Wyoming Cooperative Extension Service maintains a similar list on their energy extension website: www.wyomingrenewables.org. You can also search the phone book.

Bids

Get bids from more than one company and compare. Ask for bids on Solar Rating and Certification Corporation (SRCC)-certified systems and have the bid specify the system type, size, energy output, and maintenance requirements in addition to the cost. Ask that the bid include the following costs: installation, initial set-up (pressurizing the system, etc.), all hardware, permits, sales tax, and warranties. Some

companies will research and complete the paperwork for any available federal, state, local and utility incentives. Be sure to ask if they are including incentive deductions in their cost estimates, and be aware incentives may arrive later (rebates, etc.) and that you will typically need to pay the full, initial cost up-front.

Are You a “Handyman” or “Handywoman”?

If you decide to install your system, be sure to educate yourself and take time to attend classes, workshops, or training where you can learn from qualified instructors. Whether you hire a contractor or install the system yourself, make sure it is done correctly and safely.

References

National Renewable Energy Laboratory (produced) for the U.S. Department of Energy. (2003, December). *A Consumer's Guide: Heat Your Water with the Sun*. DOE/GO-102003-1824.

U.S. Department of Energy. (2010, October). *Building Codes, Covenants, and Regulations for Solar Water Heating Systems*. Retrieved February 8, 2011, from: http://www.energysavers.gov/your_home/water_heating/index.cfm/mytopic=12920

U.S. Department of Energy. (2010, October). *Community Solar Access*. Retrieved February 8, 2011, from: http://www.energysavers.gov/renewable_energy/solar/index.cfm/mytopic=50013

Notes



STEP 7

Steps in the Solar Hot Water Series

1. Building and Site Assessment
2. Conservation and Efficiency
3. System Options
4. System Sizing
5. Costs
6. Installation
- 7. Operation and Maintenance**
8. Solar Hot Water Collector Sizing Worksheet

E³A: Solar Hot Water Applications for the Home, Farm, or Ranch

Author: Bilo, Susan; Sarah Hamlen, Mike Vogel, and Milton Geiger, eds. E3A Program

Operation and Maintenance

Periodic inspections and routine maintenance will keep your solar hot water system running efficiently and for a long time. While the overall system can last over 40 years with proper care, active systems have electrical and mechanical parts that will need repairing or replacement before then. Active systems also require more frequent maintenance than passive systems because of the need to check pumps, heat exchangers, temperature sensors, etc. Passive systems are not recommended in cold climates.

The Installation factsheet suggests sources for finding qualified companies and contractors. These professionals may also conduct system inspections and perform maintenance tasks. Ask your system provider what is required and be sure to read the owner's manual.

It is recommended you hire a licensed and/or certified contractor, but if you plan on doing the work yourself, the following **Inspection List** gives you an idea of what is involved for an inspection (taken from the U.S Department of Energy's Energy Savers website): www.energysavers.gov/your_home/water_heating/index.cfm/mytopic=12950.

Collector shading

Visually check for shading of the collectors during the day (mid-morning, noon, and mid-afternoon) on an annual basis. Any shading can affect performance.

Collector glazing and seals

Look for cracks in the collector glazing, and check that seals are in good condition. If excessively yellowed, plastic glazing may need to be replaced.

Plumbing and wiring connections

Look for fluid leaks at pipe connections. Most leaks occur immediately after installation. All wiring connections should be tight.

Piping, duct, and wiring insulation

Look for damage or degradation of insulation covering pipes and wiring.

Roof penetrations

Flashing and sealant around roof penetrations should be in good condition.

Support structures

Check all nuts and bolts attaching the collectors to any support structures for tightness.

Pressure relief valve

Make sure the valve is not stuck open or closed.

Pumps

Verify that distribution pumps are operating. Listen to see if they come on when the sun is shining on the collectors after mid-morning. If you can't hear the pump operating, either the controller or pump has malfunctioned.



B-1279 | E3A-SH.7

©2015 E3A-SH.7 by Susan Bilo; Sarah Hamlen, Mike Vogel, and Milton Geiger eds. made available under a [Creative Commons Attribution-Non-Commercial 4.0 license \(international\)](https://creativecommons.org/licenses/by-nc/4.0/)

E3A: Solar Hot Water Applications for the Home, Farm, or Ranch is a peer-reviewed publication series.

Original available at: www.wyoextension.org/publications/

Suggested acknowledgment: Bilo, Susan; Sarah Hamlen, Mike Vogel, and Milton Geiger, eds. E3A: Solar Hot Water for the Home, Farm, or Ranch, Fact Sheet 7, Steps in the Solar Hot Water Series. E3A-SH.7. 2011.

Permission is granted to share, copy, and redistribute the material in any medium or format and adapt, remix, transform, and build upon the material for any purpose other than commercial, under the following terms:

Attribution — You must give appropriate credit, provide a link to the license, and indicate if changes were made. You may do so in any reasonable manner but not in any way that suggests the licensor endorses you or your use.

Heat transfer fluids

Antifreeze solutions in liquid solar heating collectors need to be replaced periodically. It's a task best conducted by a qualified technician. If water with a high mineral content (i.e., hard water) is circulated in the collectors, mineral buildup in the piping may need to be removed by adding a de-scaling or mild acidic solution to the water every few years.

Storage systems

Check storage tanks for cracks, leaks, rust, or other signs of corrosion.

References

National Renewable Energy Laboratory (produced) for the U.S. Department of Energy. (2003, December). *A Consumer's Guide: Heat Your Water with the Sun*. DOE/GO-102003-1824.

U.S. Department of Energy. (2010, October). *Solar Water Heating System Maintenance and Repair*. Retrieved January 25, 2011, from: http://www.energysavers.gov/your_home/water_heating/index.cfm/mytopic=12950

Notes



STEP 8

E³A: Solar Hot Water Applications for the Home, Farm, or Ranch

Author: Bilo, Susan; Sarah Hamlen, Mike Vogel, and Milton Geiger, eds. E3A Program

Steps in the Solar Hot Water Series

1. Building and Site Assessment
2. Conservation and Efficiency
3. System Options
4. System Sizing
5. Costs
6. Installation
7. Operation and Maintenance

8. Solar Hot Water Collector Sizing Worksheet

Solar Hot Water Collector Sizing Worksheet

Step 1: Calculate Your Daily Hot Water Use

| Example: A Water-Efficient Home in Helena—Daily Hot Water Use (Family of Three) | | | |
|---|-------------------------|----------------------|----------------------|
| Hot Water Use | Average Gallons Per Use | Times Per Day | Gallons Used Per Day |
| Shower | 10 | 3 | 30 |
| Automatic dishwasher | 4 | .5 (every 2 days) | 2 |
| Faucets (hand washing, food prep, etc.) | 2 | 6 | 12 |
| Automatic Clothes Washing Machine (if hot/warm water used) | 18 | .5 (every 2 days) | 9 |
| Total Daily Hot Water Use | | | *53 Gallons |

* This equals 18 gallons of hot water per person per day. Installers may assume inefficient water use and use 30 gallons of hot water per person per day to size systems. For tips on reducing hot water use and how to determine showerhead flow, visit: www.energysavers.gov/your_home/water_heating/index.cfm/mytopic=13050

| Your Daily Hot Water Use | | | |
|--|-------------------------|---------------|----------------------|
| Hot Water Use | Average Gallons Per Use | Times Per Day | Gallons Used Per Day |
| Shower | | | |
| Automatic dishwasher | | | |
| Faucets (hand washing, food prep, etc.) | | | |
| Automatic Clothes Washing Machine (if hot/warm water used) | | | |
| Other | | | |
| Other | | | |
| Total Daily Hot Water Use | | | |



B-1279 | E3A-SH.8

©2015 E3A-SH.8 by Susan Bilo; Sarah Hamlen, Mike Vogel, and Milton Geiger eds. made available under a [Creative Commons Attribution-Non-Commercial 4.0 license \(international\)](https://creativecommons.org/licenses/by-nc/4.0/)

E3A: Solar Hot Water Applications for the Home, Farm, or Ranch is a peer-reviewed publication series.

Original available at: www.wyoextension.org/publications/

Suggested acknowledgment: Bilo, Susan; Sarah Hamlen, Mike Vogel, and Milton Geiger, eds. E3A: Solar Hot Water for the Home, Farm, or Ranch, Fact Sheet 8, Steps in the Solar Hot Water Series. E3A-SH.8. 2011.

Permission is granted to share, copy, and redistribute the material in any medium or format and adapt, remix, transform, and build upon the material for any purpose other than commercial, under the following terms:

Attribution — You must give appropriate credit, provide a link to the license, and indicate if changes were made. You may do so in any reasonable manner but not in any way that suggests the licensor endorses you or your use.

Step 2: Calculate the Energy Needed to Heat Your Water

Formula: Volume (in gallons) x Temperature Rise (°F) x 8.33 (a constant) = Energy Load (in Btu)

Helena Example: 53 Gallons x 80°F x 8.33 = 35,319 Btu/day

Your Home/Building: _____ Gallons X _____ °F X 8.33 = _____ Btu/day

- Volume = Total Daily Hot Water Use # from Step 1.
- Temperature Rise: the difference between the temperature of the cold water coming into your home or building and the temperature setting on your hot water heater. For Helena, Mont., and Cheyenne, Wyo., incoming water is 40°F; If the water heater is set at 120°F, the temperature rise (difference) is 80°F (120-40= 80°F). Go to: <http://calc.rinnai.us/residentialapp.aspx?&SID=4vueps2a2uq04labawfxooy0> for the incoming temperature of your water. You only need your zip code.
- 8.33 is a formula constant; it represents the density of water multiplied by its specific heat.
- Btu – British Thermal Units

Step 3: Determine Your Site's Average Daily Solar Energy (Radiation)

Find your city or the city nearest your site for your average daily Solar Radiation:

| Table A: Solar Radiation Data for Flat-Plate Collectors (south-facing, fixed tilt at latitude angle) | | | |
|--|-------------------------|----------------|-------------------------|
| Montana Cities | kWh/m ² /day | Wyoming Cities | kWh/m ² /day |
| Billings | 5.0 | Casper | 5.3 |
| Cut Bank | 4.8 | Cheyenne | 5.3 |
| Glasgow | 4.7 | Lander | 5.6 |
| Great Falls | 4.8 | Rock Springs | 5.5 |
| Helena | 4.7 | Sheridan | 5.0 |
| Kalispell | 4.1 | | |
| Lewistown | 4.7 | | |
| Miles City | 5.0 | | |
| Missoula | 4.3 | | |

Source: U.S. DOE/National Renewable Energy Laboratory (NREL): <http://rredc.nrel.gov/solar/pubs/redbook/>

Step 4: Convert Your Answer into Btu/ft²/day

Conversion Formula: 1 kWh/m²/day = 317.1 Btu/ft²/day

Helena Example: 4.7 kWh/m²/day x 317.1 = 1,490 Btu/ft.²/day

Your Site: _____ kWh/m²/day x 317.1 = _____ Btu/ft²/day

Steps 5-7 provide information that will be used when accessing the Solar Rating & Certification Corporation's (SRCC) website list of solar hot water collectors.

Step 5: Determine Your Site's Sky Type

Take your site's average daily solar energy number from Step 4, and using this table, determine your site's Sky Type.

| SRCC "Sky Type" Rating Table | |
|------------------------------|---------------|
| Btu/ft ² /day | Sky Type |
| 2,000 | Clear |
| 1,500 | Mildly Cloudy |
| 1,000 | Cloudy |

Using the Helena Example, 1,490 Btu/ft²/day is closest to 1,500 Btu/ft²/day; thus, Mildly Cloudy will be

used as the Sky Type for sizing the collector.

Step 6: Finding the Appropriate Category Letter

The SRCC's collector listing allows you to choose from the following Categories:

- A: Pool Heating (Warm Climates)
- B: Pool Heating (Cool Climates)
- C: Water Heating (Warm Climates)
- D: Water Heating (Cool Climates) <— *Category used for the Helena example.*
- E: Air Conditioning (space conditioning)

Step 7: Determine the Collector Type

Glazed flat-plate or evacuated tubes are typically used for residential solar hot water systems in Montana and Wyoming. Decide which one you will install for selecting the "Optic Type" option once on the website. For the Helena example, we will select a Glazed Flat-Plate collector, and Liquid as the "Fluid" option.

Step 8: Find Certified Solar Hot Water Collectors

Website: www.solar-rating.org

- Select -> Ratings (left-hand column)
- Select -> Glazed Flat-Plate under the Optic Type options, and Liquid under the Fluid Option.
- If you have a specific company or brand name you prefer, select those options.
- Select -> Show Selections



SUPPLIER:
Rheem Water Heaters
 101 Bell Rd
 Montgomery, AL 36117 USA
www.rheem.com

In Accordance with:
SRCC Standard 100-2005-09

CERTIFIED SOLAR COLLECTOR

BRAND: Rheem
MODEL: RS40-BC
COLLECTOR TYPE: Glazed Flat Plate
CERTIFICATION #: 2009094C
Original Certification: October 29, 2009
Expiration Date: June 21, 2019

The solar collector listed below has been evaluated by the Solar Rating & Certification Corporation™ (SRCC™), an ISO/IEC 17065 accredited and EPA recognized Certification Body, in accordance with SRCC OG-100, Operating Guidelines and Minimum Standards for Certifying Solar Collectors, and has been certified by the SRCC. This award of certification is subject to all terms and conditions of the Program Agreement and the documents incorporated therein by reference. This document must be reproduced in its entirety.

| COLLECTOR THERMAL PERFORMANCE RATING | | | | | | | |
|--|---|---|--|------------------------------------|---|---|--|
| Kilowatt-hours (thermal) Per Panel Per Day | | | | Thousands of Btu Per Panel Per Day | | | |
| Climate -> | High Radiation (6.3 kWh/m ² .day) | Medium Radiation (4.7 kWh/m ² .day) | Low Radiation (3.1 kWh/m ² .day) | Climate -> | High Radiation (2000 Btu/ft ² .day) | Medium Radiation (1500 Btu/ft ² .day) | Low Radiation (1000 Btu/ft ² .day) |
| Category (Ti-Ta) | | | | Category (Ti-Ta) | | | |
| A (-5 °C) | 16.4 | 12.3 | 8.3 | A (-9 °F) | 55.9 | 42.1 | 28.3 |
| B (5 °C) | 15.1 | 11.1 | 7.0 | B (9 °F) | 51.6 | 37.7 | 24.0 |
| C (20 °C) | 13.0 | 9.0 | 5.1 | C (36 °F) | 44.3 | 30.7 | 17.3 |
| D (50 °C) | 8.4 | 4.8 | 1.5 | D (90 °F) | 28.8 | 16.5 | 5.0 |
| E (80 °C) | 4.0 | 1.1 | 0.0 | E (144 °F) | 13.7 | 3.8 | 0.0 |

A- Pool Heating (Warm Climate) **B-** Pool Heating (Cool Climate) **C-** Water Heating (Warm Climate)
D- Space & Water Heating (Cool Climate) **E-** Commercial Hot Water & Cooling

You will see a list of collectors that have been tested and rated by the SRCC. The complete page (not shown) provides the collector specifications, including gross area, as well as materials and technical information. *This is not an endorsement of the Rheem Company or its products; Rheem was chosen for the sole purpose of providing an example.*

Using Mildly Cloudy and Category D, this collector will produce 16.5 thousands of Btu per panel (collector) per day. Divide by 1,000 to get kBtu units.

$$16,500 \text{ Btu/collector/day} \div 1,000 = 16.5 \text{ kBtu/collector/day}$$

Because there are inefficiencies in the complete solar hot water system (heat loss through storage tanks, pipes, etc.), a rule of thumb is to multiply the collector's rated output by 80% for a more accurate estimate of how much energy it will produce.

$$16.5 \text{ kBtu/collector/day} \times .80 = 13.2 \text{ kBtu/collector/day}$$

Your Collector Choice: _____ kBtu/collector/day \times .80 = _____ kBtu/collector/day

NOTE: The A – E Category letters are based upon the difference between the temperature of the water entering the collector (T_i) and the temperature around the collector (T_a). Category C may be more accurate during warmer months for most of Montana and Wyoming; thus, consider that using an average of several Categories may be needed for more accurate sizing.

Step 9: Determine how many collectors are needed to provide your hot water

This will be based upon how much energy is needed to heat your water (Calculated in Step 2).

$$\text{Helena Example (\#s from Step 2): } 53 \text{ Gallons} \times 80^\circ \text{ F} \times 8.33 = 35,319 \text{ Btu/day}$$

$$35,319 \text{ Btu/day} \div 1,000 = 35.3 \text{ kBtu/day}$$

Next, divide the Helena home's hot water energy requirement by the chosen panel's output.

$$35.3 \text{ kBtu/day} \div 13.2 \text{ kBtu/collector/day} = 2.6 \text{ collectors (round-up to 3)}$$

Thus, three of the selected collectors would be needed to produce 100% of the Helena home's hot water. Two collectors would provide 75% of the home's hot water needs.

Your Home/Building (insert #'s from Step 2): _____ Gallons \times _____ $^\circ\text{F}$ \times 8.33 = (a) _____ Btu/day

$$(a) \text{ _____ Btu/day} \div 1,000 = (b) \text{ _____ kBtu/day}$$

From Step 8: _____ kBtu/collector/day output \times .80 = (c) _____ kBtu/collector/day

$$(b) \text{ _____} \div (c) \text{ _____} = \text{_____} \text{ (\# of collectors needed to provide 100\% of your hot water).}$$

NOTE: To take advantage of the current federal 30% Residential Renewable Energy Tax Credit, "solar water heating property must be certified by SRCC or a comparable entity endorsed by the state where the system is installed. At least 50% of the energy used to heat the dwelling's water must be from solar."

Reference

Bickford, Carl. (2007, April/May). *Sizing Solar Hot Water Systems*. Home Power, 118, 34-38.